

EndoPure 120™



HTM2030, HTM01-06 & ENISO 15883 purified water for Endoscopy

Environmental Water Systems (UK) Ltd introduces our integrated reverse osmosis, ultraviolet light and filtration system specifically designed to meet the requirements for endoscope washer disinfectors used within hospitals.

- Designed to comply with the principles of HTM 2030, proposed HTM01-06 and the European standard EN ISO 15883
- Compact and easy to manoeuvre unit, no bigger than a single three drawer filing cabinet
- Will fit below a standard work surface
- Multiple technologies to produce the required purity of water
- Production rate 120 litres/hour with delivery rates up to 35 l/min for single washers
- Microprocessor controlled on-line monitoring at all times
- Minimal water wastage
- Continuous and intermittent recirculation facility
- Simple sanitisation
- Hygienic sample valve to validate and verify product water quality
- CE marked

Environmental Water Systems (UK) Ltd
Charwell House, Cheddar Business Park
Wedmore Road, Cheddar, Somerset BS27 3EB
Tel: 01934 741782 Fax: 01934 741783
Email: enquiries@reverseosmosis.co.uk



Environmental Water Systems (UK) Ltd
Total Capability in Water Purification and Water Treatment



EndoPure 120™

Flow diagram

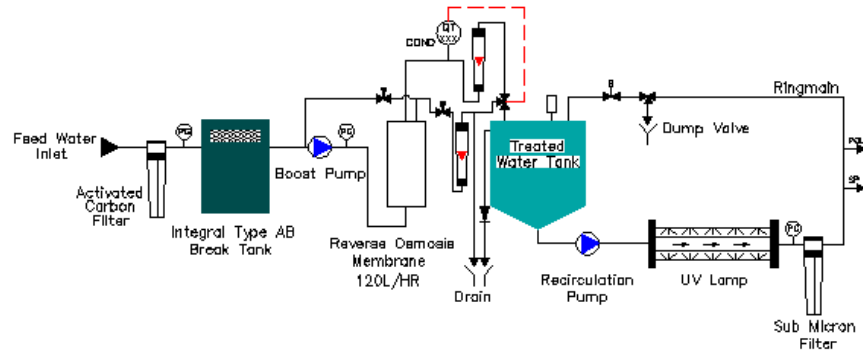

Technical specifications

RO120

Performance specifications

Conductivity	< 30 μ S/cm
Bacteria	< 10 CFU/100ml
Endotoxin	< 0.25 EU/ml
Particles	< 0.2 microns

Product specification

Product production rate @ 10°C	120 l/hr
Product delivery rate	Up to 35 l/min
*Recovery rate (max)	30%
Dimensions: H x W x D (mm)	1000 x 600 x 650
Shipping weight (approx)	90kgs
Inlet pipe dimensions	½" BSP
Outlet pipe dimensions	½" BSP
Drain from RO	12 mm
RO pump motor	0.55 kW
Delivery/recirculation pump	0.55 kW
Operational modes	Power on, RO on, Service, Water good, Water bad, Permeate and concentrate flows, Inlet, Outlet and RO pressures

Feed water specifications

General	Potable water free from organics, colloids and suspended matter
Total dissolved solids	< 1000 mg/l
Free Chlorine	0.1 ppm
Temperature	5-40°C
Pressure	3-6 bar
Silt density index	< 3 SDI units

Environmental Water Systems (UK) Ltd
 Charwell House, Cheddar Business Park
 Wedmore Road, Cheddar, Somerset BS27 3EB
 Tel: 01934 741782 Fax: 01934 741783
 Email: enquiries@reverseosmosis.co.uk



Environmental Water Systems (UK) Ltd
 Total Capability in Water Purification and Water Treatment

